



MTG

No limits innovation



INS.3.2.1

PROMET III-Locking for Plate Lip Shrouds (Sizes 70-160)

Installation procedure

DISCLAIMER

© MTG, all rights reserved

The brands identified with an asterisk do not belong to METALOGENIA S.A. and this organization refers to them only to identify the destination of its products, without there being any relationship between METALOGENIA S.A. and the legitimate owners of any such brands.

Copy right: It is strictly forbidden for any person not belonging to MTG to distribute all or any part of the material set out in this document unless they are authorized to do so.

Liability: To ensure the correct use and handling of the MTG products without risk, please carefully read the corresponding service instructions set out on the MTG website. MTG will not be held liable for damages, loss, injury, or death arising from incorrect use or failure to heed the provisions of this guide. Similarly, MTG will not be held liable for damages caused due to the faulty installation or handling of its products. MTG likewise declines all liability for recommendations related to the use or handling of MTG products set out in documents not expressly authorized by MTG.

1. SAFETY

The practices described in this manual can be taken as guidelines for operating safely in many conditions and in addition to the safety standards that are current and enforceable in your area or region.

Your safety and the safety of third parties is the result of putting into practice your knowledge of the correct operational procedures.

Attention, when performing the work described in these instructions, always work safely and use the personal protection elements required to minimize or avoid injury. Always wear:



To avoid eye injury, always wear safety goggles or a protective mask when using any equipment, hammer or similar tool. When equipment is under pressure or when objects are struck, chips or other debris can be thrown out. Make sure no one gets hurt by the debris that is fired before applying pressure or hitting an object. Wear eye protection that complies with ANSI Z87.1 and OSHA standards. Also wear hearing protection and gloves.

Lifting a heavy object can cause serious or fatal injury. **DO NOT** exceed the maximum rated capacity of lifting and positioning devices: Stay away from the area under a suspended load.

Make sure that the chain is not damaged and that the load is always balanced.



LIFTING LUG

2. WELDING

Following is a quick reference on consumables that can be used to weld MTG products. For a complete reference on welding procedures, refer to the document entitled "General welding recommendations".

WELDING UNALLOYED FILLER CONSUMABLES

PROCESS	EN CLASS	AWS CLASS
SMAW	EN ISO 2560-S E42X	E70X ACCORDING TO A5.1 OR EQUIVALENT UNDER A5.5
	EN ISO 14341-A G42X	E70C-X ACCORDING TO A5.18 OR EQUIVALENT UNDER A5.28
GMAW	EN ISO 14341-A G46X	E70S-X ACCORDING TO A5.18 OR EQUIVALENT UNDER A5.28
	EN ISO 16834-A T42X	E7XT-X ACCORDING TO A5.20 OR EQUIVALENT UNDER A5.29
FCAW		

WELDING AUSTENITIC STAINLESS FILLER CONSUMABLES

PROCESS	AWS CLASS
SMAW	E307-X ACCORDING TO A5.4
	ER307T-X ACCORDING TO A5.22
GMAW	ER307 ACCORDING TO A5.9
FCAW	307-X ACCORDING TO A5.22

NOTE: "X" MAY STAND FOR ONE OR SEVERAL CHARACTERS

3. IMPORTANT

Read the full document prior to start any operation since there may be some steps which may require previous verifications/operations.



This document only refers to shrouds of sizes 70 to 160, for shrouds of smaller sizes, review the installation procedure INS.3.2.5 PROMET III locking for Plate Lip shrouds (Sizes 40-60).

4. WELD-ON BASE INSTALLATION PROCEDURE

Prior to start the welding process, the correct placement of the weld-on base shall be ensured following the steps hereafter described:

- 4.1** Place the shroud on the blade on its selected location. The shroud must be in contact with the frontal surface of the blade (1). Insert the weld-on base from the back of the shroud. **Note:** Do not weld the base on this stage yet.

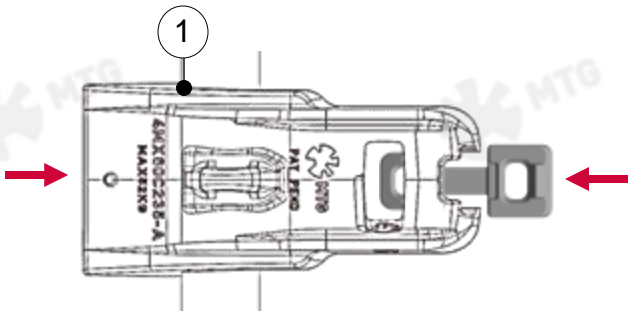

- 4.2** Insert the mechanical block on its housing being sure that the weld-on base is now trapped between the shroud and the mechanical block.

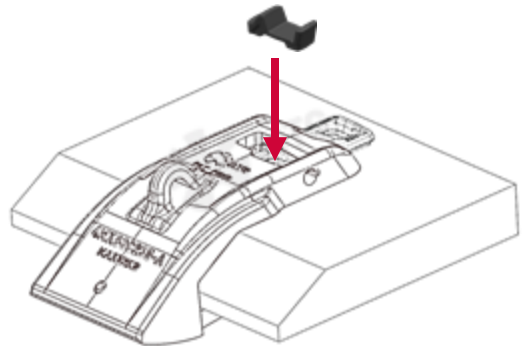

- 4.3** Insert a shim (according to the table) in the front part of the block (between the block and the weld-on base). Then, insert a pry bar between the shroud and the weld-on base at [1], then pull the weld-on base towards the back of the bucket [2], being sure that the shroud keeps full contact with the front of the lip [3].

Be sure that while pulling the weld-on base back, the shroud is contacting the lip's front surface at [3] and the mechanical block at [4].

SHIM THICKNESS ACCORDING TO SIZE

SIZE	A	
	[MM]	[INCHES]
70-90	1	1/32
100-160	2	1/16

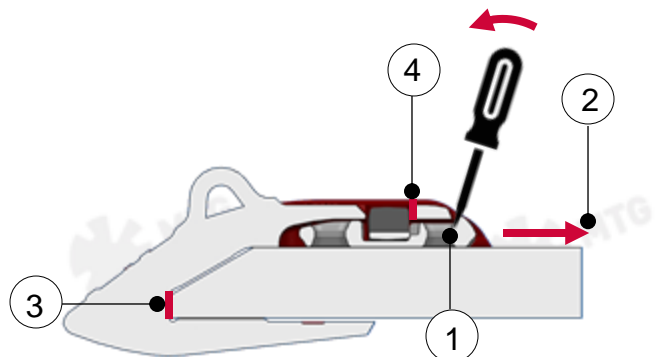
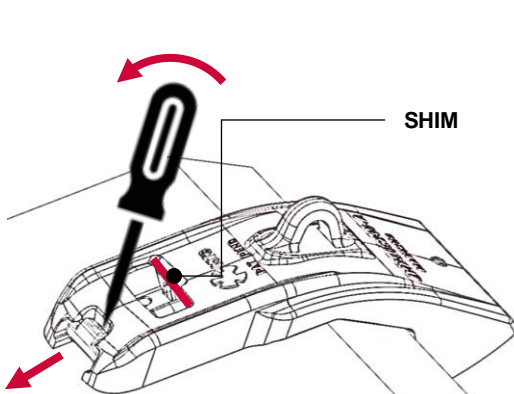

4.4 While pulling the weld-on base back with the pry bar, perform a couple of tack welds [1] at the rear part of the weld-on base (grooves at the external visible part of the weld-on base).

Important: Prior to any weld operation, lip and weld-on base should be pre-heated to a temperature between 175°C and 200°C (347°F and 392°F) in an area of 100mm (4") around. Lip and base should also accomplish the assembly conditions as it is described into the document entitled: "General welding recommendations".

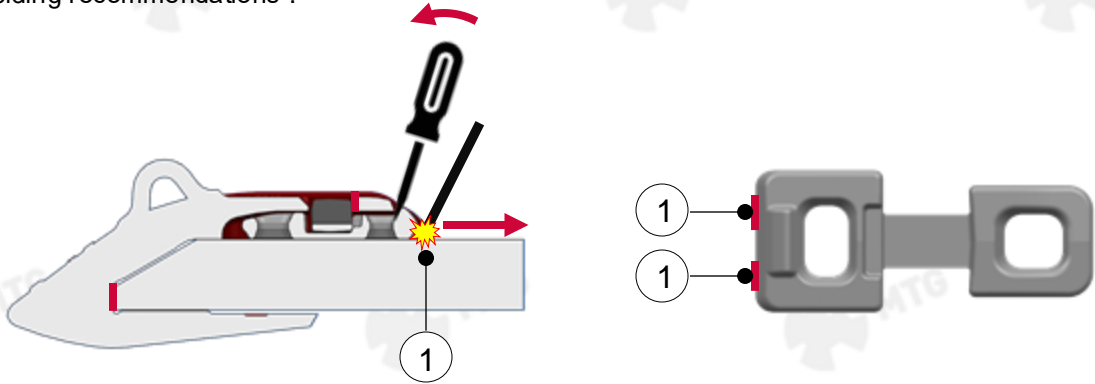

4.5 Prior to the welding completion of the weld-on base, the proper position of the weld-on base should be verified. The following points must be checked:

- In a correct assembly, there must be gap between the shroud and the tab of the weld-on base
- In a correct assembly, the front part of the weld-on base must be visible
- In a correct assembly, there must be gap between the shroud and the mechanical block
- In a correct assembly, there must be no gap between the shroud and the mechanical block
- In a correct assembly, the gap between the shroud and the tab of the weld-on base is the same in both cases, the assembly with the weld-on base and with all components.

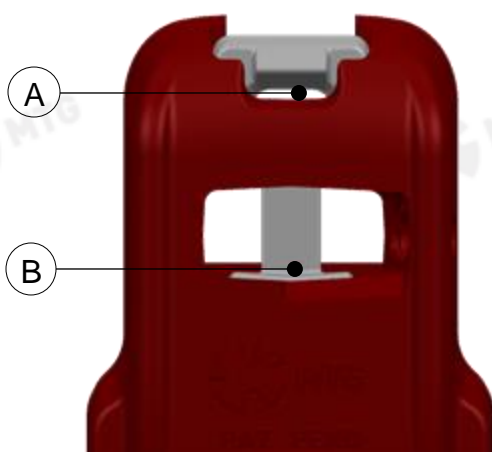

ASSEMBLY WITH WELD-ON BASE

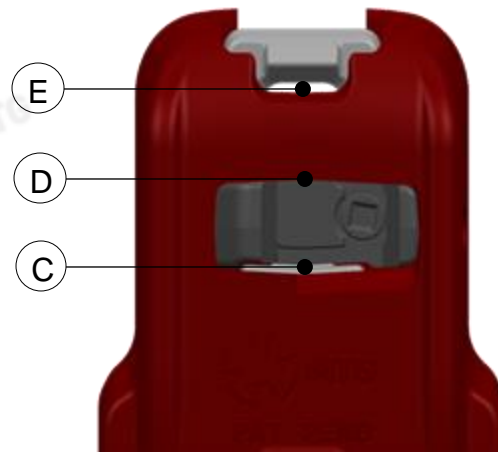

ASSEMBLY WITH ALL COMPONENTS

4.6 Remove the mechanical block and the shroud.

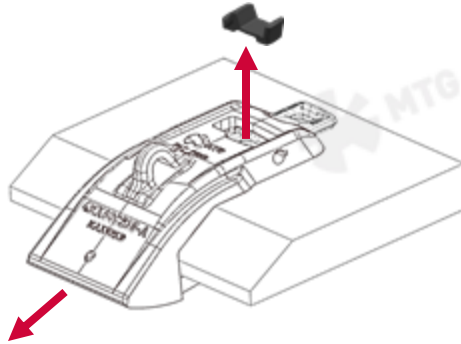

4.7 Check that the preheating temperatures are still within specs and preheat if necessary. Then, perform all weld beads following the sequence shown on the figure. Be sure that the bottom side of the weld-on base keeps contact with the blade along all the welding process.

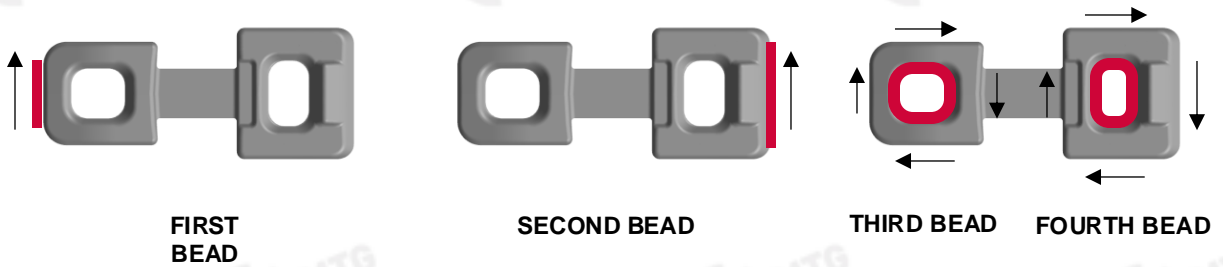

4.8 The welding beads must be continuous and must not exceed the 3,2mm (1/8") above the welding preparation chamfer.

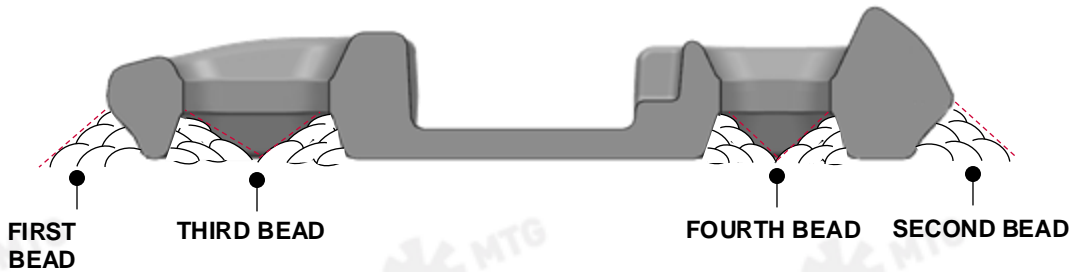

4.9 All welding grooves must be completely full. Lack of welding can lead to product failures.

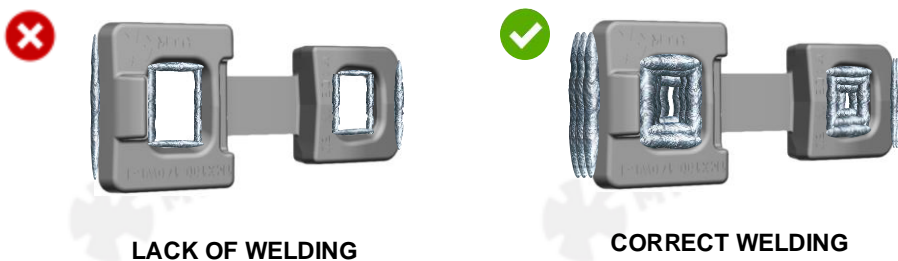

4.10 Ensure that the welding technique comply with what is exposed on the document entitled: “General welding recommendations”.

4.11 Grinding shall produce a smooth surface free of roughness and unevenness associated with the weld beads. The toes of the welds shall merge smoothly with the lip and the adapter with a minimum radius of 4mm - 5/32 in.

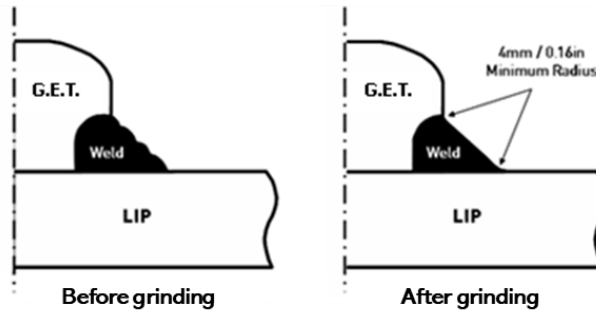

4.12 Grinding shall be done using high speed electric or pneumatic grinders with grinding wheels no larger than 50mm - 2 in. in diameter. **ANGLE HEAD OR DISK GRINDERS ARE NOT ALLOWED FOR THIS WORK.**

Grinding shall be done with the perimeter of the wheel and not the face. The grinding direction must be perpendicular to the toes of the welds as in the illustration.

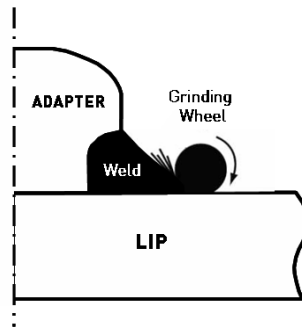

Proper Grinding Directions:

Grinding the radio at the toes of the welds is facilitated using cone-shaped grinding wheels. For final grinding, the abrasive may be no coarser than 24 Grit.

4.13 After welding completion, all welds shall be subjected to visual and magnetic particle inspection, as described on “General welding recommendations”. Any detected welding crack must be cleaned and repaired.

5. SHROUD ASSEMBLY

- 5.1** Insert the lip shroud on its station through the weld-on base by hoisting it with a crane and the lifting lug.

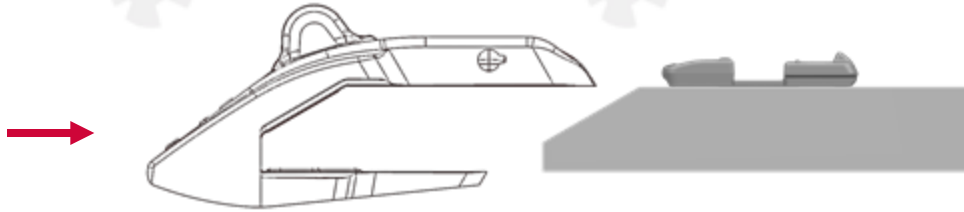

- 5.2** Insert the mechanical block on its housing between the weld-on base and the shroud. At this stage, the shroud can no longer move.

NOTE: Pay special attention at the position of the hole for the screw, it must be located at the right side, as the image show.

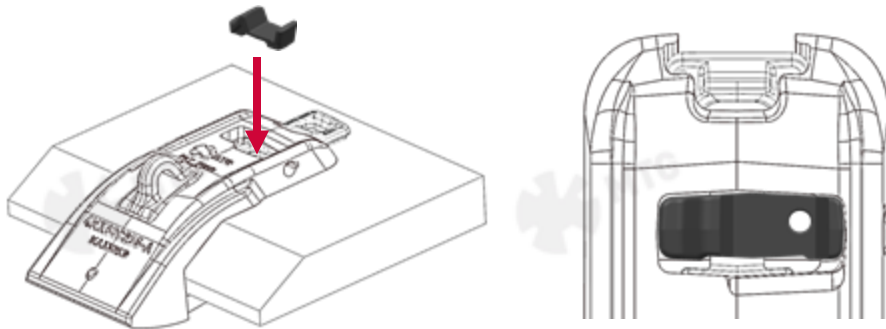

- 5.3** Insert the locking plate on its housing into the mechanical block and slide it towards the inside of the bucket until its hole and the one on the mechanical block are concentric.

Then insert the bolt and screw it until a torque of 150 Nm (110 lb-ft). Finally, insert the plug into the bolt's head to prevent it from dirt.

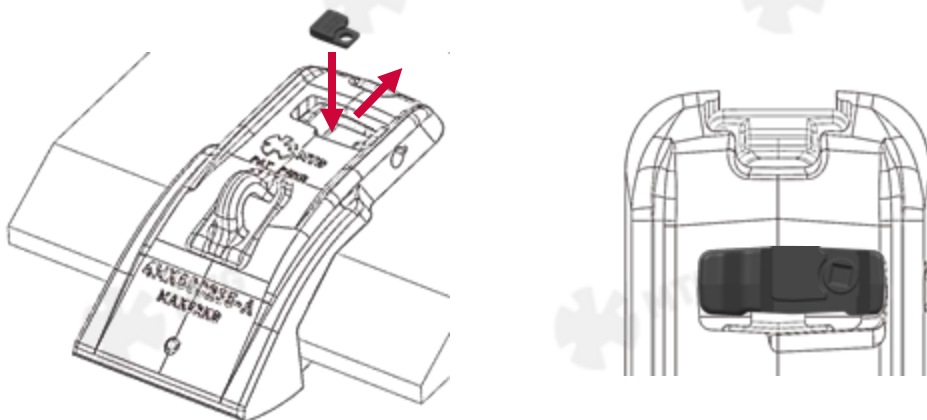

6. SHROUD REMOVAL

- 6.1** Clean the fines stuck behind the locking plate by means of a needle gun. Then, remove the plug from the bolt's head and unscrew the bolt until release it. An electric or pneumatic rattle gun can ease the operation.

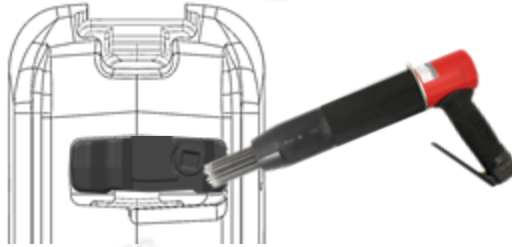

- 6.2** Slide the locking plate back and pull it out. A further cleaning might be necessary to ease the operation.

- 6.3** Extract the mechanical block.

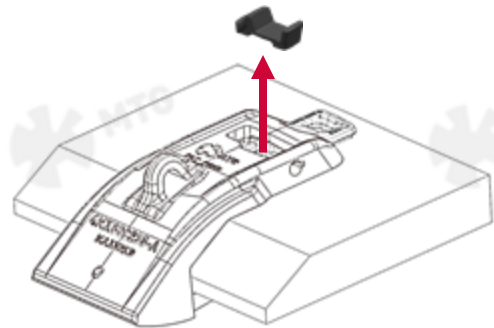
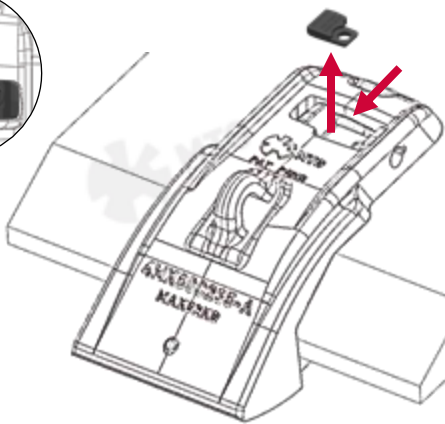
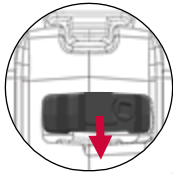

- 6.4** Weld a lifting lug to the shroud and pull it out by means of a crane.

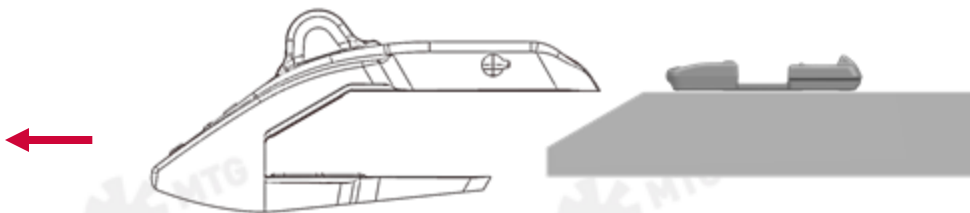



Service Instructions

The latest welding recommendations and assembly / disassembly instructions can be found online:

www.mtgcorp.com/manuals

Please contact Technical Services in case of questions:

technical.services@mtgcorp.com



MTG HEADQUARTERS

Carrer d'Àvila, 45
08005 Barcelona (Spain)
(+34) 93 741 70 00
info@mtgcorp.com

MTG NORTH AMERICA

4740 Consulate Plaza Drive
Houston, TX 77032 (USA)
+1 (281) 872 1500
Info.na@mtgcorp.com

MTG AUSTRALIA

16 – 18 Thorpe Close
Welshpool, WA, 6106 (AUS)
+61 8 6248 6513
Info.au@mtgcorp.com