

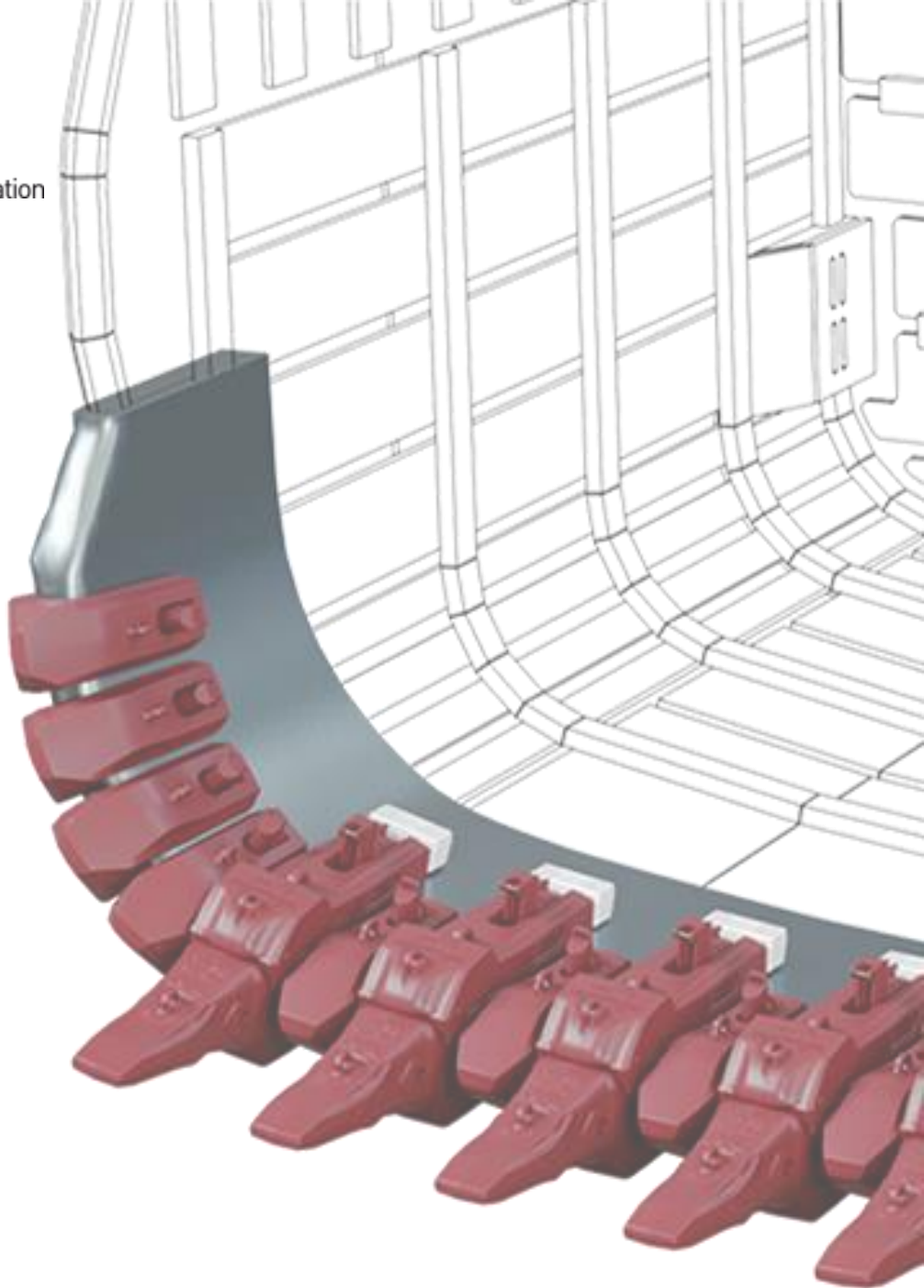

**MTG**

No limits innovation



**INS.2.6.2**

# **Conventional 3-part CR Adapter Locking**

Installation procedure

## DISCLAIMER

### © MTG, all rights reserved

The brands identified with an asterisk do not belong to METALOGENIA S.A. and this organization refers to them only to identify the destination of its products, without there being any relationship between METALOGENIA S.A. and the legitimate owners of any such brands.

**Copy right:** It is strictly forbidden for any person not belonging to MTG to distribute all or any part of the material set out in this document unless they are authorized to do so.

**Liability:** To ensure the correct use and handling of the MTG products without risk, please carefully read the corresponding service instructions set out on the MTG website. MTG will not be held liable for damages, loss, injury, or death arising from incorrect use or failure to heed the provisions of this guide. Similarly, MTG will not be held liable for damages caused due to the faulty installation or handling of its products. MTG likewise declines all liability for recommendations related to the use or handling of MTG products set out in documents not expressly authorized by MTG.

## 1. SAFETY

The practices described in this manual can be taken as guidelines for operating safely in many conditions and in addition to the safety standards that are current and enforceable in your area or region.

Your safety and the safety of third parties is the result of putting into practice your knowledge of the correct operational procedures.

Attention, when performing the work described in these instructions, always work safely and use the personal protection elements required to minimize or avoid injury. Always wear:



To avoid eye injury, always wear safety goggles or a protective mask when using any equipment, hammer or similar tool. When equipment is under pressure or when objects are struck, chips or other debris can be thrown out. Make sure no one gets hurt by the debris that is fired before applying pressure or hitting an object. Wear eye protection that complies with ANSI Z87.1 and OSHA standards. Also wear hearing protection and gloves.

Lifting a heavy object can cause serious or fatal injury. DO NOT exceed the maximum rated capacity of lifting and positioning devices: Stay away from the area under a suspended load.



**LIFTING LUG**

Make sure that the chain is not damaged and that the load is always balanced.

## 2. RELEVANT INFORMATION

The following instructions are a generic procedure for all MTG adapters for cable shovels, independent from the standard lip (WH/BK), the size of the adapter and the tooth system they use.

The images contained in this procedure may not correspond to the model used in each case.

## 3. INSTALLATION PROCEDURE

**CAUTION:** The installation of MTG products for cable shovels may require reconstructive work on the lip, such as welding and grinding, to return it to its original geometry and ensure proper fit and performance.

To perform the reconstruction/recalibration of lips, it is mandatory to follow the MTG reparation instructions for rope shovels which describe the proper procedures for recovering the lip geometry by using MTG gauges. Please contact [technical.services@mtg.es](mailto:technical.services@mtg.es) for further information.

**3.1** Place the adapter on its station ensuring contact on the curved edge as shown in the picture.

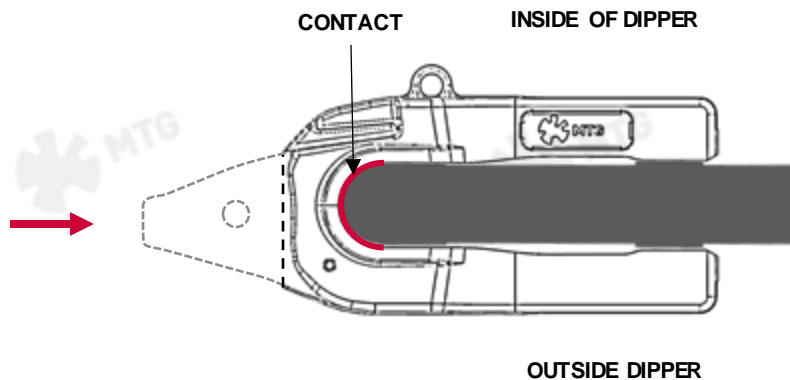

**3.2** Put the C-clamp on its position. Introduce it always with the handle from the inside of the dipper.

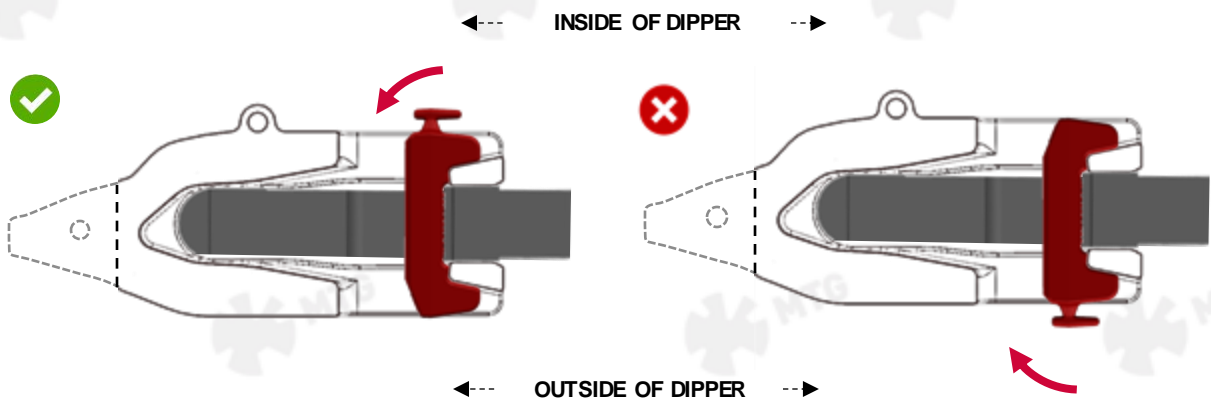

**3.3** Place the inverted wedge on the forward edge of the lip hole.

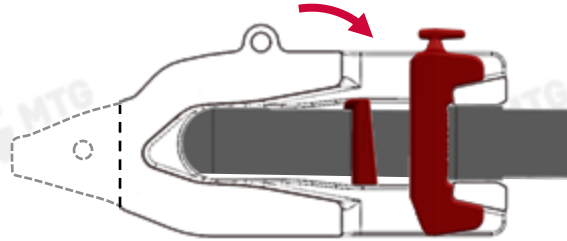

**3.4** Introduce the wedge (size 1) into its housing matching analog faces and hit it down with a heavy hammer ( $\geq 10$  Kg - 25 lbs.) until the wedge does not move further.

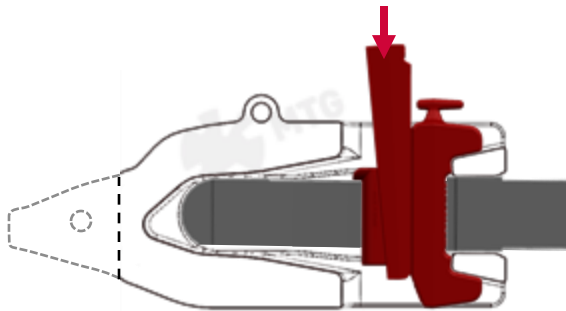

**3.5** Once the wedge is in its final position, the following situations must be considered:

**A)** The mounting is considered correct when the wedge protrudes ("X")  $100 \pm 38$ mm ( $4 \pm 1.5$ " ) above the adapter.

**B)** If the wedge protrudes more than 100mm ("X") (4") above the adapter, it is recommended to make a cut as shown in the image.

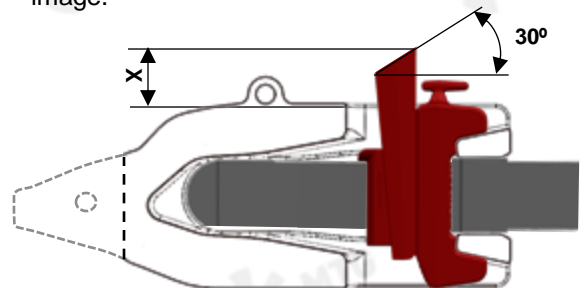
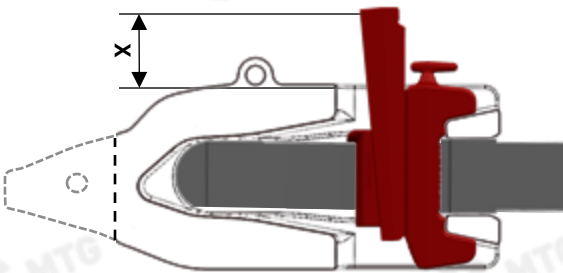

**C)** If the wedge protrudes less than 50mm (2") above the adapter, the mounting is not satisfactory, and the wedge size 2 must be installed. In any case, any portion of wedge protruding from the bottom of the adapter must be cut.

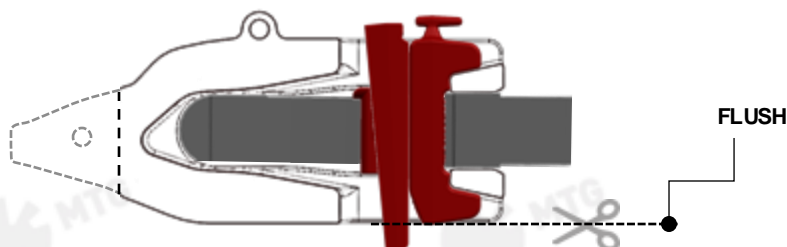

**3.6** If necessary, install the wedge size 2 by following the instructions given in steps 3.3, 3.4 and 3.5.

## 4. REMOVAL PROCEDURE

4.1 Place the dipper on a safe position to operate the locking from the top.

4.2 Clean out all the fines stuck in the cavity where the inverted wedge is located until the flange is visible.

4.3 By blowtorch or air arc, make a cut in the tab of the inverted wedge at a dimension  $x = 20\text{mm}$  (3/4") from its end.

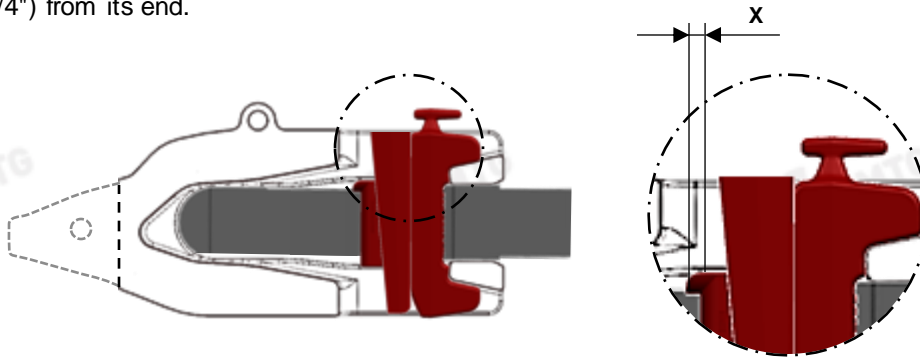

4.4 Place an extracting rod into the inverted wedge's top surface and hit it down with a heavy hammer ( $\geq 10\text{ Kg}$  - 25 lbs.) until the flange get broken. After breaking this flange, the inverted wedge will fall out of its housing. Once the forward wedge is out, the wedge will fall through the hole too.

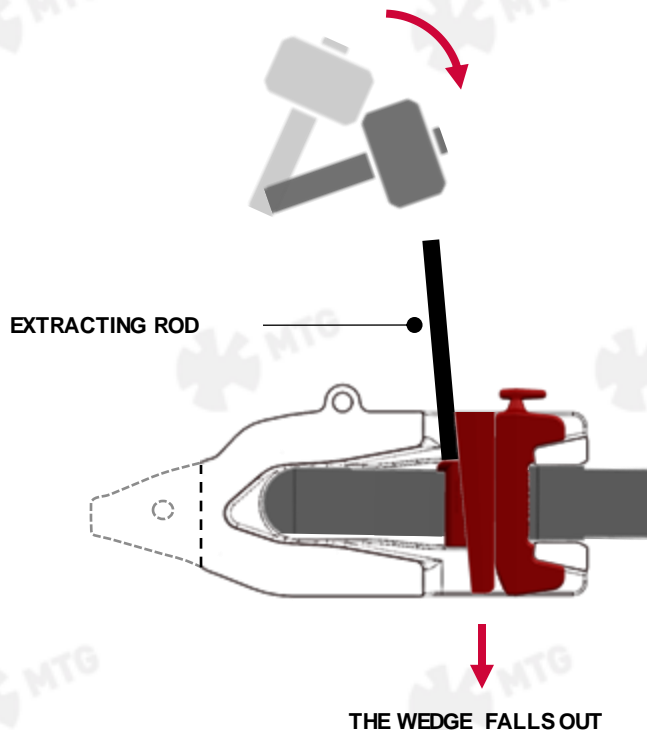

4.5 Once the wedge is out, push the c-clamp so that it falls through the hole. Then, remove the adapter.



## Service Instructions

The latest welding recommendations and assembly / disassembly instructions can be found online:

[www.mtgcorp.com/manuals](http://www.mtgcorp.com/manuals)

Please contact Technical Services in case of questions:

[technical.services@mtg.es](mailto:technical.services@mtg.es)



---

### MTG HEADQUARTERS

Carrer d'Àvila, 45  
08005 Barcelona (Spain)  
(+34) 93 741 70 00  
info@mtg.es

### MTG NORTH AMERICA

4740 Consulate Plaza Drive  
Houston, TX 77032 (USA)  
+1 (281) 872 1500  
info@mtgcorp.us

### MTG AUSTRALIA

16 – 18 Thorpe Close  
Welshpool, WA, 6106 (AUS)  
+61 8 6248 6513  
Info.australia@mtg.es