



MTG

No limits innovation



INS.3.3.3

PROMET UX-S Wing Shroud (Sizes 80-140)

Installation procedure

DISCLAIMER

© MTG, all rights reserved

The brands identified with an asterisk do not belong to METALOGENIA S.A. and this organization refers to them only to identify the destination of its products, without there being any relationship between METALOGENIA S.A. and the legitimate owners of any such brands.

Copy right: It is strictly forbidden for any person not belonging to MTG to distribute all or any part of the material set out in this document unless they are authorized to do so.

Liability: To ensure the correct use and handling of the MTG products without risk, please carefully read the corresponding service instructions set out on the MTG website. MTG will not be held liable for damages, loss, injury, or death arising from incorrect use or failure to heed the provisions of this guide. Similarly, MTG will not be held liable for damages caused due to the faulty installation or handling of its products. MTG likewise declines all liability for recommendations related to the use or handling of MTG products set out in documents not expressly authorized by MTG.

1. SAFETY

The practices described in this manual can be taken as guidelines for operating safely in many conditions and in addition to the safety standards that are current and enforceable in your area or region.

Your safety and the safety of third parties is the result of putting into practice your knowledge of the correct operational procedures.

Attention, when performing the work described in these instructions, always work safely and use the personal protection elements required to minimize or avoid injury. Always wear:



To avoid eye injury, always wear safety goggles or a protective mask when using any equipment, hammer or similar tool. When equipment is under pressure or when objects are struck, chips or other debris can be thrown out. Make sure no one gets hurt by the debris that is fired before applying pressure or hitting an object. Wear eye protection that complies with ANSI Z87.1 and OSHA standards. Also wear hearing protection and gloves.

Lifting a heavy object can cause serious or fatal injury. DO NOT exceed the maximum rated capacity of lifting and positioning devices: Stay away from the area under a suspended load.



LIFTING LUG

Make sure that the chain is not damaged and that the load is always balanced.

2. WELDING

Following is a quick reference on consumables that can be used to weld MTG products. For a complete reference on welding procedures, refer to the document entitled "General welding recommendations".

WELDING UNALLOYED FILLER CONSUMABLES

PROCESS	EN CLASS	AWS CLASS
SMAW	EN ISO 2560-S E42X	E70X ACCORDING TO A5.1 OR EQUIVALENT UNDER A5.5
	EN ISO 14341-A G42X	E70C-X ACCORDING TO A5.18 OR EQUIVALENT UNDER A5.28
GMAW	EN ISO 14341-A G46X	E70S-X ACCORDING TO A5.18 OR EQUIVALENT UNDER A5.28
	EN ISO 16834-A T42X	E7XT-X ACCORDING TO A5.20 OR EQUIVALENT UNDER A5.29

WELDING AUSTENITIC STAINLESS FILLER CONSUMABLES

PROCESS	AWS CLASS
SMAW	E307-X ACCORDING TO A5.4
	ER307T-X ACCORDING TO A5.22
GMAW	ER307 ACCORDING TO A5.9
	307-X ACCORDING TO A5.22

NOTE: "X" MAY STAND FOR ONE OR SEVERAL CHARACTERS

3. IMPORTANT

Read the full document prior to start any operation since there may be some steps which may require previous verifications/operations.



This document only refers to sizes 80 to 140, for smaller size protectors, see installation procedure INS.3.3.7 PROMET UX-S Wing Shroud (Sizes 40-60).

4. PREPARATION

Prior to the installation of the shrouds, it is necessary to perform a chamfer to break the sharp edges of the cheek plate by means of grinding.

The recommended dimensions for those chamfers are according to the following table and its length shall be enough to cover the total length of all the shrouds installed on that cheek.

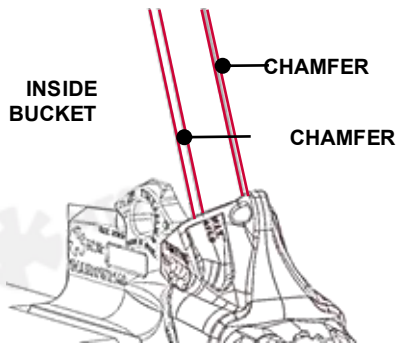

CHEEK DIMENSIONS

SIZE	CHEEK THICKNESS		CHAMFER SIZE	
	[MM]	[INCHES]	[MM]	[INCHES]
80	80	3 1/8	12x12	1/2 x 1/2
90	90	3 9/16	12x12	1/2 x 1/2
120	120	4 3/4	12x12	1/2 x 1/2
140	140	5 1/2	12x12	1/2 x 1/2

5. WELD-ON BASE AND STOPPERS INSTALLATION PROCEDURE

5.1 Place the wing shroud on the desired position close to the lower wing shroud, wear cap or adapter keeping frontal contact at all time.

The minimum gap recommendable between parts is 12mm (1/2"). The longest strap of the shroud should be facing the outside of the bucket.

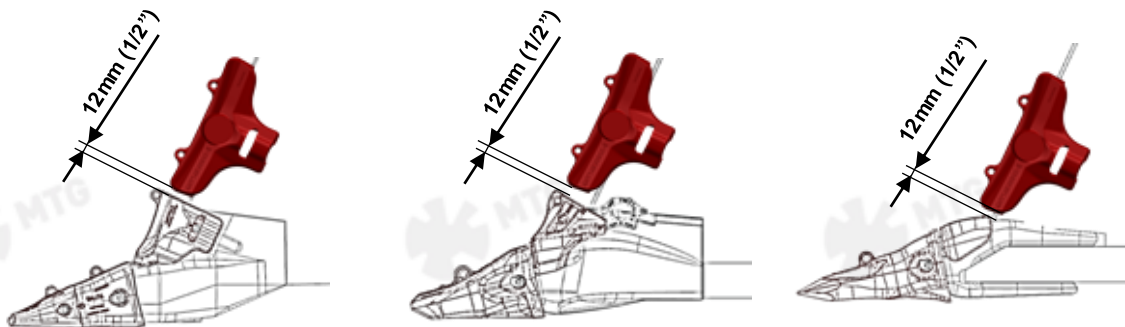

In case of interference between the wearcap and wing stoppers, the wing stopper should be cut off as shown below:

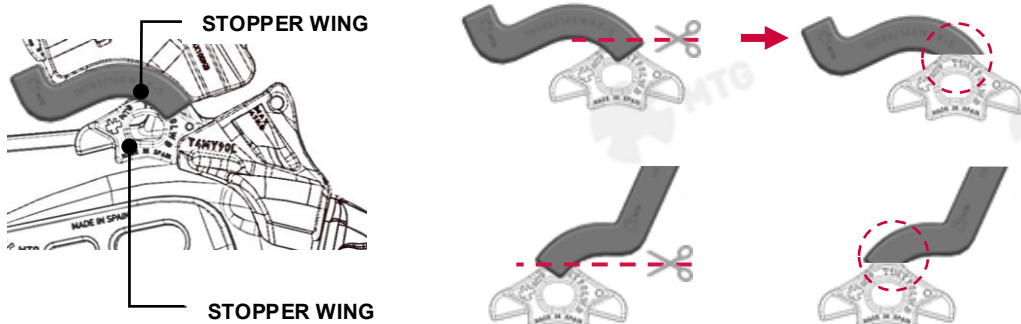

5.2 Hold the shroud in place with the help of a crane and insert the weld-on base completely until it lands flush on its housing.

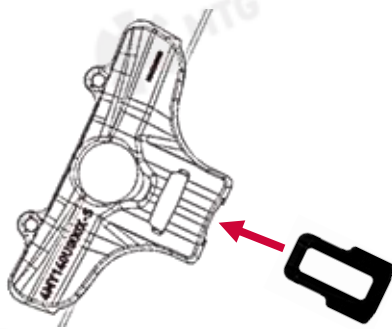

5.3 Insert the mechanical block into its housing being sure that the engraving “FRONT” is facing the cutting edge of the protector. Once the mechanical block is on its proper place, the weld-on base should get trapped.

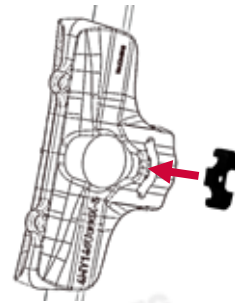

5.4 Being sure that the shroud is properly contacting the edge of the cheek and the mechanical block is fully inserted into its housing, insert a 2mm (1/16”) shim at the front of the block, between the block and the Weld-on base and pull the weld-on base out as much as possible with the help of a lever, pry bar or similar.

Preheat cheek and base to a temperature between 175°C and 200°C (347°F and 392°F) at a distance of 100mm (4”) all around the welding area and tack-weld the weld-on base to the cheek where the picture shows.

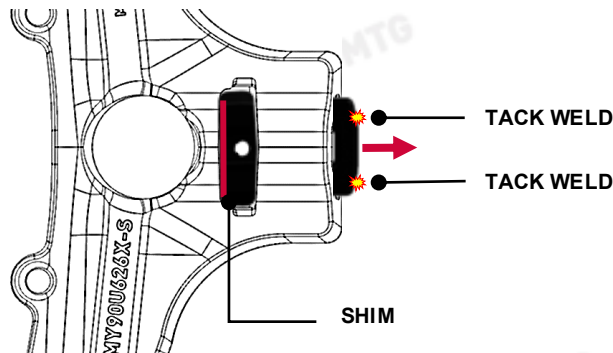

5.5 Take the shim and mechanical block out and leave the shroud on its location. Check that the pre-heating temperature is still within the recommended temperatures and tack-weld the weld-on base where the picture shows. With this step we will assure the position of the weld-on base.

Be sure that those tack-welds not protrude from the welding grooves.

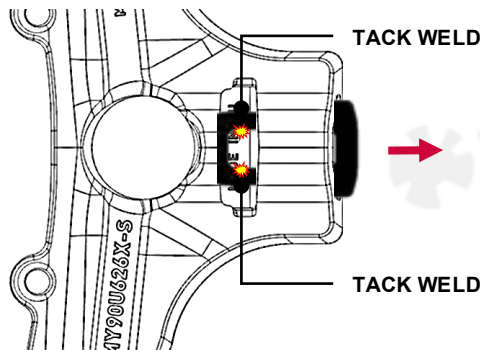

5.6 Insert the mechanical block again and place the outer stoppers on its proper position contacting the shroud as the picture shows.

Note that there is **GAP** at the end of the shroud.

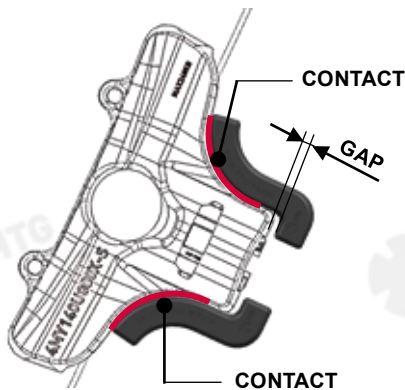

5.7 Check that the pre-heating temperature is still within the recommended range and tack-weld the stoppers as the picture shows.

Be sure that the stoppers do not tilt, and they remain in contact with the cheek plate during the process.

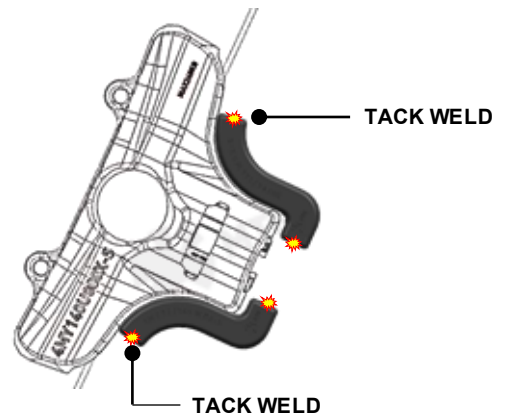

5.8 Without removing neither the shroud nor the mechanical block, place the inner stopper on its proper position contacting the shroud as the picture shows.

Note that there is **GAP** at the end of the shroud.

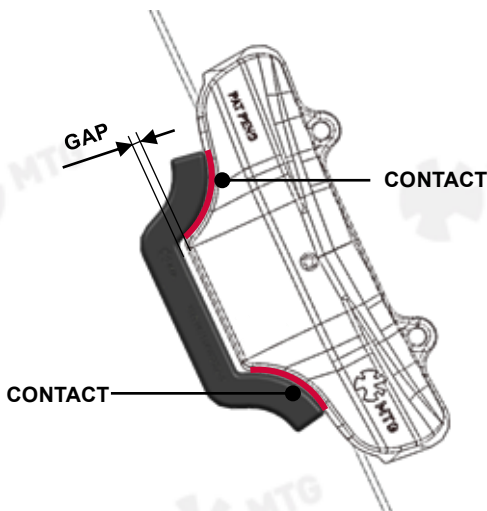

5.9 Check that the pre-heating temperature is still within the recommended range and tack-weld the stopper as the picture shows.

Be sure that the stoppers do not tilt, and they remain in contact with the cheek plate during the process.

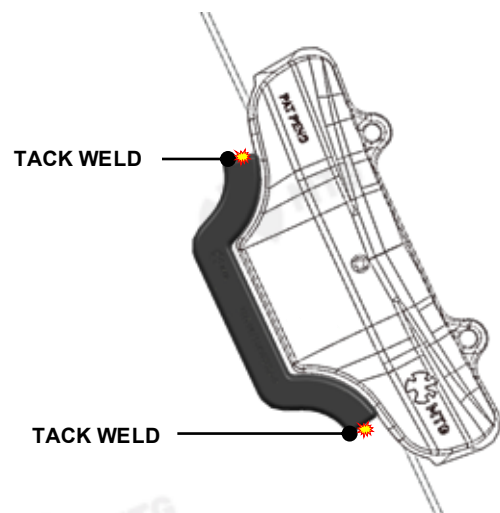

5.10 Remove the mechanical block and the shroud to complete the welding of the base and stoppers.

5.11 Check that the pre-heating temperature is still within the recommended. If necessary, preheat again to the indicated temperatures, between 175°C and 200°C (347°F and 392°F) in an area of 100 mm (4") around the area to be welded.

Proceed with the welding of the weld-on base in the indicated areas, filling the welding groove according to the color code indicated in the following figure. Do not weld outside the marked areas or exceed 250°C (482°F) during the welding process.

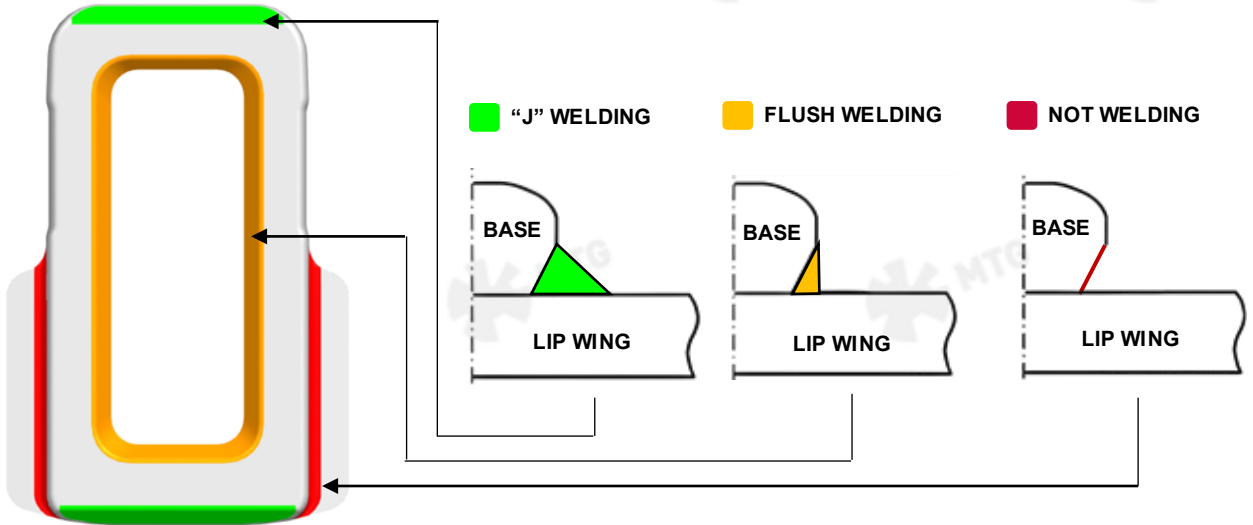

BOTTOM VIEW OF THE BASE

5.12 Check that the pre-heating temperature is still within the recommended range and proceed with the welding of the outer stoppers by filling the indicated welding grooves completely. Do not weld at the areas which are not indicated.

The previous tack-welds are not necessary to be removed unless there are any interference with the shroud once installed.

5.13 Check that the pre-heating temperature is still within the recommended range and proceed with the welding of the inner stopper by filling the indicated welding grooves completely.

The previous tack-welds are not necessary to be removed unless there are any interference with the shroud once installed.

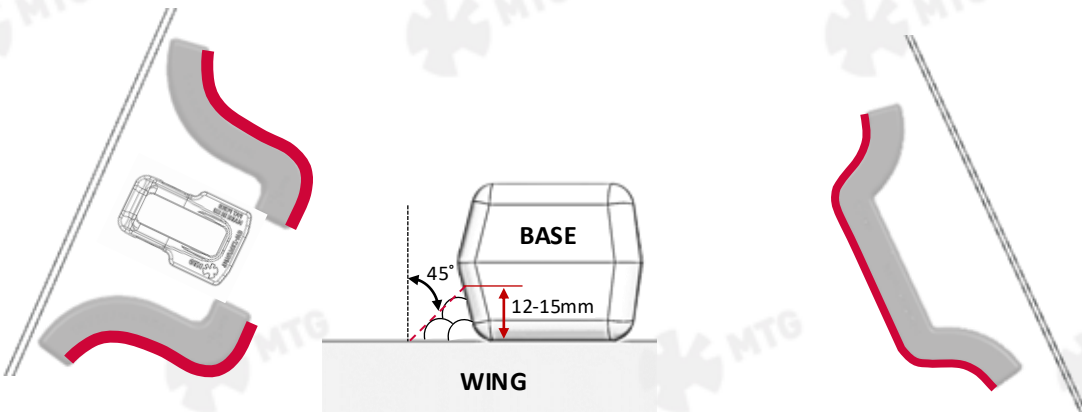

5.14 Repeat steps from 5.1 to 5.13 to install the desired number of shrouds.

5.15 Once the welding process has been finished proceed with the welding inspection according what is stated in the document entitled: GENERAL WELDING RECOMMENDATIONS.

In case of finding any crack indication, proceed with the crack reparation by grinding or gouging the area and filling by welding. Be aware that prior to any operation in which heat is involved a pre-heating to the recommended temperatures is mandatory.

5.16 If the welding inspection has finished with no indications, we recommend performing one of the welding dressing indicated in the GENERAL WELDING RECOMMENDATIONS.

6. WING SHROUD INSTALLATION PROCEDURE

6.1 Place the shroud into its location sliding it through the weld-on base guides.

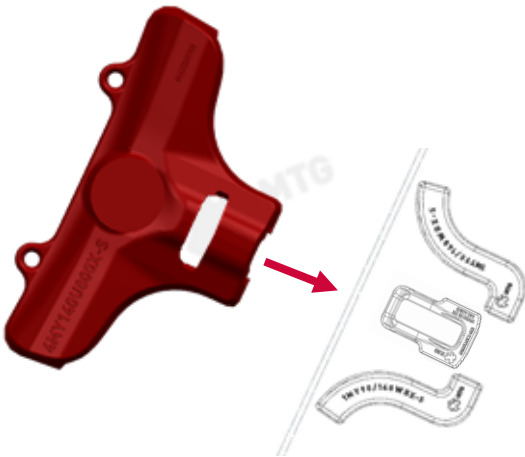

6.2 Remove the bolt and plate from the mechanical block assembly and insert it into its housing on the shroud. Be sure that the engraving "FRONT" of the block is facing the shroud cutting edge.

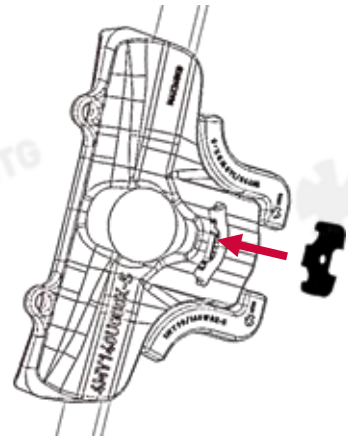

6.3 Insert the plate into its housing as the picture shows and slide it in until the mechanical block and plate holes are concentric.

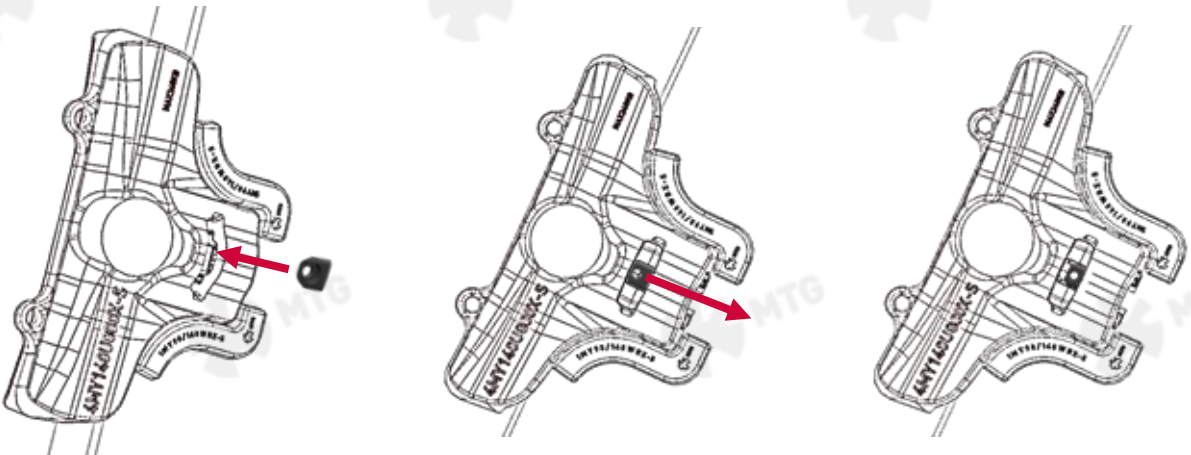

- 6.4** Insert the bolt into the hole and tighten it by means of a 19mm (3/4") square drive to a torque of 300 ± 50 Nm ($221,3 \pm 37$ lbf). Insert the plug into the bolt square to prevent the entry of fines.

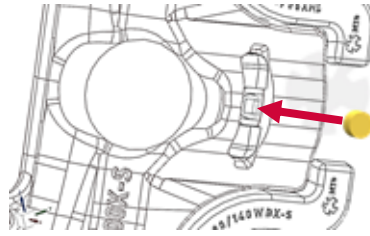

7. WING SHROUD REMOVAL PROCEDURE

- 7.1** Clean out the fines trapped into the bolt square hole, remove the plug and untighten the bolt to remove it.

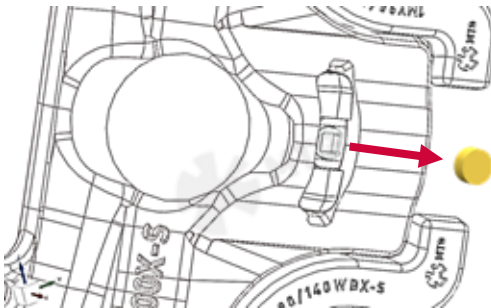

- 7.2** Slide the plate back by pulling it from the hole by means of a screwdriver or similar and take the it out.

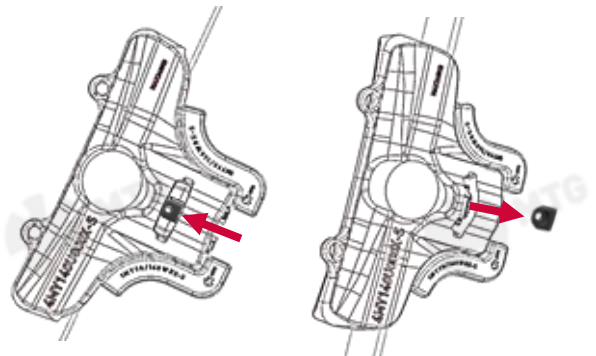

- 7.3** Take the mechanical block out by means of a screwdriver, lever, pry bar or similar by levering it out from its 2 ends simultaneously or alternating one and the other.

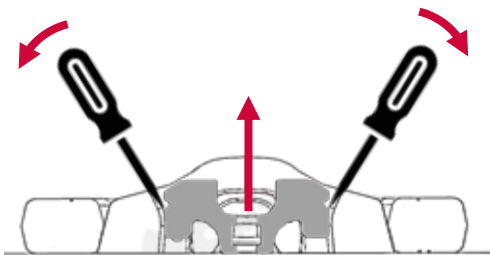

- 7.4** Take the shroud out with the help of a crane and clean out the fines attached to the weld-on base and stoppers before installing a new shroud.

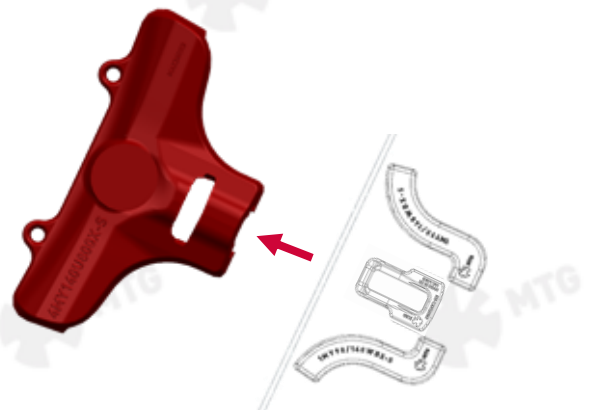



Service Instructions

The latest welding recommendations and assembly / disassembly instructions can be found online:

www.mtgcorp.com/manuals

Please contact Technical Services in case of questions:

technical.services@mtgcorp.com



MTG HEADQUARTERS

Carrer d'Àvila, 45
08005 Barcelona (Spain)
(+34) 93 741 70 00
info@mtgcorp.com

MTG NORTH AMERICA

4740 Consulate Plaza Drive
Houston, TX 77032 (USA)
+1 (281) 872 1500
Info.na@mtgcorp.com

MTG AUSTRALIA

16 – 18 Thorpe Close
Welshpool, WA, 6106 (AUS)
+61 8 6248 6513
Info.au@mtgcorp.com