



MTG

No limits innovation



INS.2.2.3

WS Straddle Weld-on Adapter

Installation procedure

DISCLAIMER

© MTG, all rights reserved

The brands identified with an asterisk do not belong to METALOGENIA S.A. and this organization refers to them only to identify the destination of its products, without there being any relationship between METALOGENIA S.A. and the legitimate owners of any such brands.

Copy right: It is strictly forbidden for any person not belonging to MTG to distribute all or any part of the material set out in this document unless they are authorized to do so.

Liability: To ensure the correct use and handling of the MTG products without risk, please carefully read the corresponding service instructions set out on the MTG website. MTG will not be held liable for damages, loss, injury, or death arising from incorrect use or failure to heed the provisions of this guide. Similarly, MTG will not be held liable for damages caused due to the faulty installation or handling of its products. MTG likewise declines all liability for recommendations related to the use or handling of MTG products set out in documents not expressly authorized by MTG.

1. SAFETY

The practices described in this manual can be taken as guidelines for operating safely in many conditions and in addition to the safety standards that are current and enforceable in your area or region.

Your safety and the safety of third parties is the result of putting into practice your knowledge of the correct operational procedures.

Attention, when performing the work described in these instructions, always work safely and use the personal protection elements required to minimize or avoid injury. Always wear:



To avoid eye injury, always wear safety goggles or a protective mask when using any equipment, hammer or similar tool. When equipment is under pressure or when objects are struck, chips or other debris can be thrown out. Make sure no one gets hurt by the debris that is fired before applying pressure or hitting an object. Wear eye protection that complies with ANSI Z87.1 and OSHA standards. Also wear hearing protection and gloves.

Lifting a heavy object can cause serious or fatal injury. DO NOT exceed the maximum rated capacity of lifting and positioning devices: Stay away from the area under a suspended load.

Make sure that the chain is not damaged and that the load is always balanced.



LIFTING LUG

2. WELDING

Following is a quick reference on consumables that can be used to weld MTG products. For a complete reference on welding procedures, refer to the document entitled "General welding recommendations".

WELDING UNALLOYED FILLER CONSUMABLES

PROCESS	EN CLASS	AWS CLASS
SMAW	EN ISO 2560-S E42X	E70X ACCORDING TO A5.1 OR EQUIVALENT UNDER A5.5
	EN ISO 14341-A G42X	E70C-X ACCORDING TO A5.18 OR EQUIVALENT UNDER A5.28
GMAW	EN ISO 14341-A G46X	E70S-X ACCORDING TO A5.18 OR EQUIVALENT UNDER A5.28
	EN ISO 16834-A T42X	E7XT-X ACCORDING TO A5.20 OR EQUIVALENT UNDER A5.29

WELDING AUSTENITIC STAINLESS FILLER CONSUMABLES

PROCESS	AWS CLASS
SMAW	E307-X ACCORDING TO A5.4
	ER307T-X ACCORDING TO A5.22
GMAW	ER307 ACCORDING TO A5.9
	307-X ACCORDING TO A5.22

NOTE: "X" MAY STAND FOR ONE OR SEVERAL CHARACTERS

3. IMPORTANT

Read the full document prior to start any operation since there may be some steps which requires previous verifications/operations.



These instructions are a generic procedure for all MTG weld-on straddle adapter regardless the nose system they have.

4. INITIAL CONSIDERATIONS

4.1 CONSIDERATIONS REGARDING THE GAP

- 4.1.1** The gap between the adapter's upper leg and the lip must be not greater than 4mm - 3/16 in (Gap size)

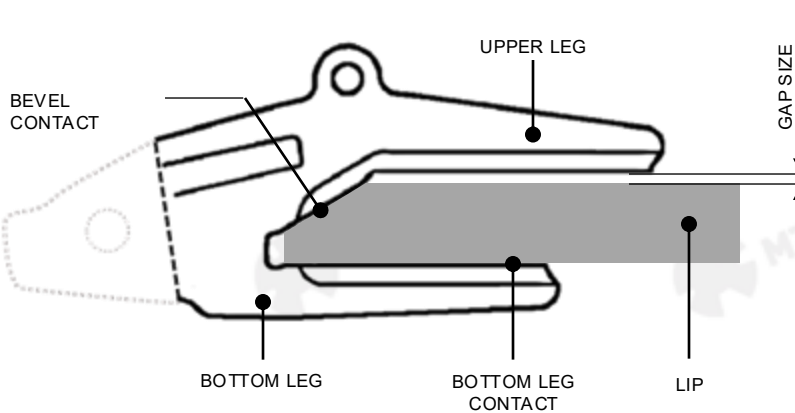

- 4.1.2** If the gap between the adapter and the blade is higher than the previously specified, a low carbon sheet-metal must be placed in between to cover the gap. This sheet must contour the contact area of the adapter's upper leg (without overpassing that profile) and be welded all together (adapter and shim) to the blade.

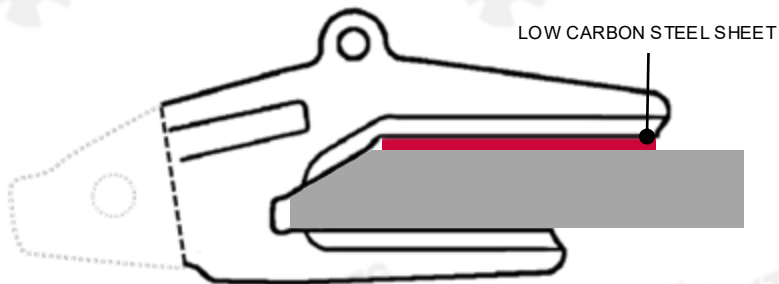

- 4.1.3** Alternatively, the adapter's upper leg may be built up by welding to acceptable gap in the following manner:

1. Clean the surfaces of any contaminants.
2. Preheat adapter's leg to 175°C - 347°F
3. Deposit stringer bead(s) along the adapter to reduce the gap condition.
4. Grind weld so that there is a smooth transition in the weld groove area of the adapter.
5. Check if adapter fit on the lip. Grind or weld as required to eliminate gap condition.

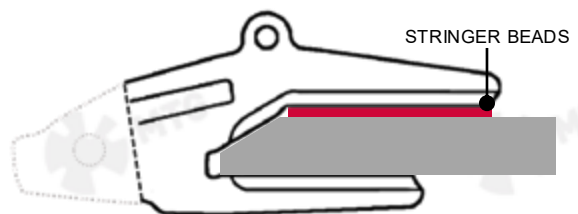

4.1.4

If the room between the adapter's legs is small to fit the lip (interference), grinding along the interfering upper leg is permissible.

If more than 3.2mm - 1/8 in. is removed from the weld preps of the adapter's upper leg, the weld prep must be widened to restore the original "J" groove weld size.

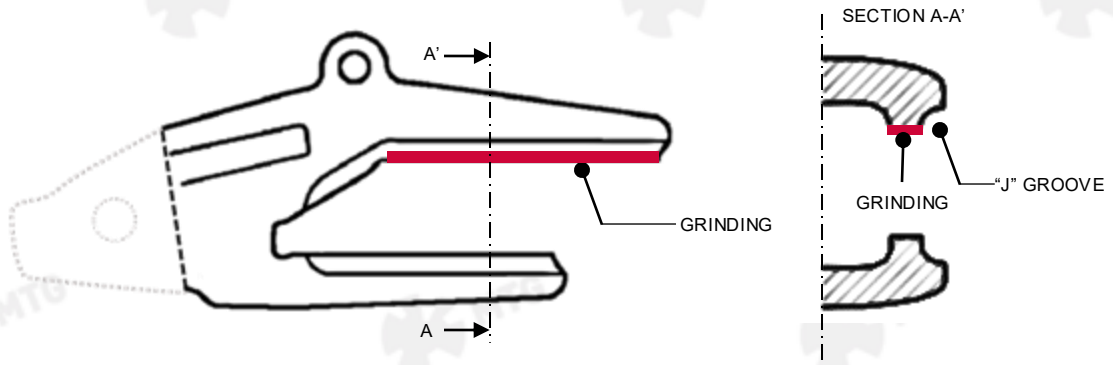

4.2 GENERAL CONSIDERATIONS

The following statements should be taken into consideration:

1. If the lower corner wear cap is expected to be installed, check its installation procedure first before proceeding with any other operation over the adapters.
2. All mill scale, rust, paint, oil grease, arc air slag, or moisture shall be removed from the surfaces within 12.5 mm - 1/2 in. of any weld location. The surfaces must be sufficiently clean so that there is nothing that might contain moisture or hydrocarbons, which could break down in the arc's heat producing hydrogen that can be absorbed in the weld causing cracks. Removal may be accomplished by shot blasting, sand blasting, grinding, or machining. Any porosity, burned-in sand, or other defects visible on the weld prep surfaces must be removed by grinding or arc air gouging.
3. After placing the adapter on its position along the lip, and prior to any welding, assure that the bottom leg and bevel are in full contact with the lip as indicated in the picture below.

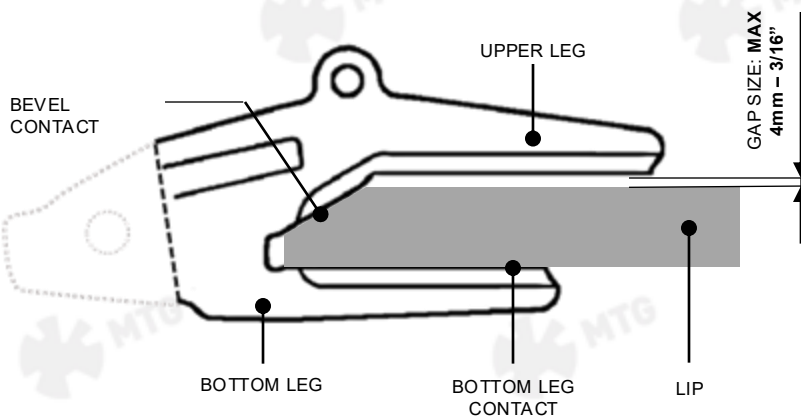

5. INSTALLATION PROCEDURE

5.1 WELDING OF ADAPTERS

5.1.1 Preheat adapter and lip to a temperature between 175°C to 200°C - 347°F to 392°F within an offset of 100mm - 4 in. all around according to what is exposed on the document entitled "General welding recommendations". Do not overpass 250°C - 480°F.

5.1.2 Consider the areas to be welded and those that do not need to be welded according to the following figures:



PERSPECTIVE VIEW

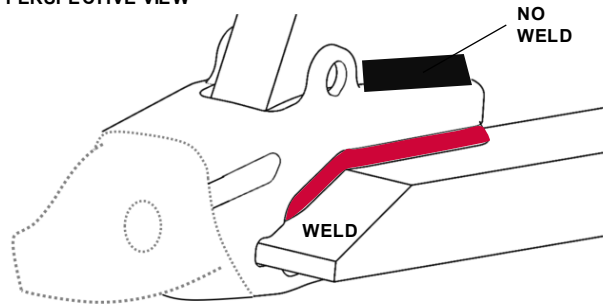

SECTION A-A'

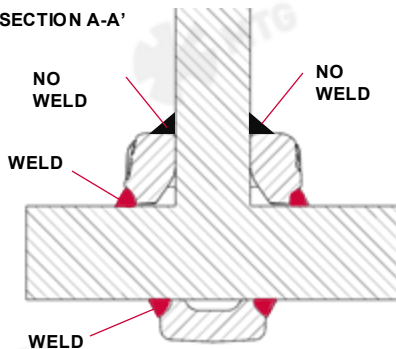

TOP VIEW

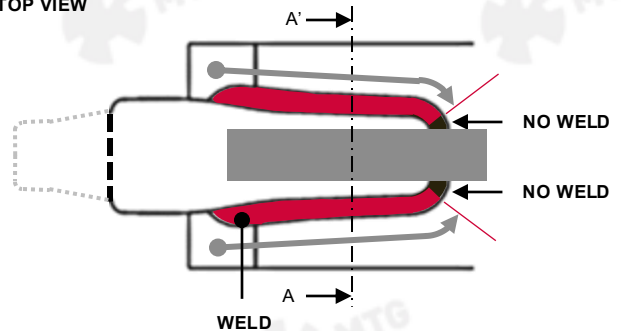

5.1.3 Apply one 25mm - 1 in. long tack weld at the root of the weld groove on each side of the top leg, midway between the end of the leg and the trailing edge of the lip level.

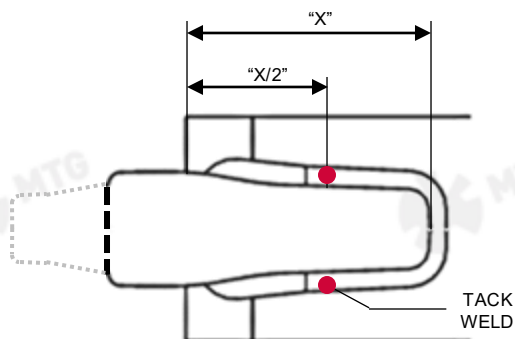

5.1.4 Begin welding at the center of top leg and weld one pass according to the sequence shown in the next figure. Do not weld within “d1” distance, from the lip leading edge, as shown the below table.

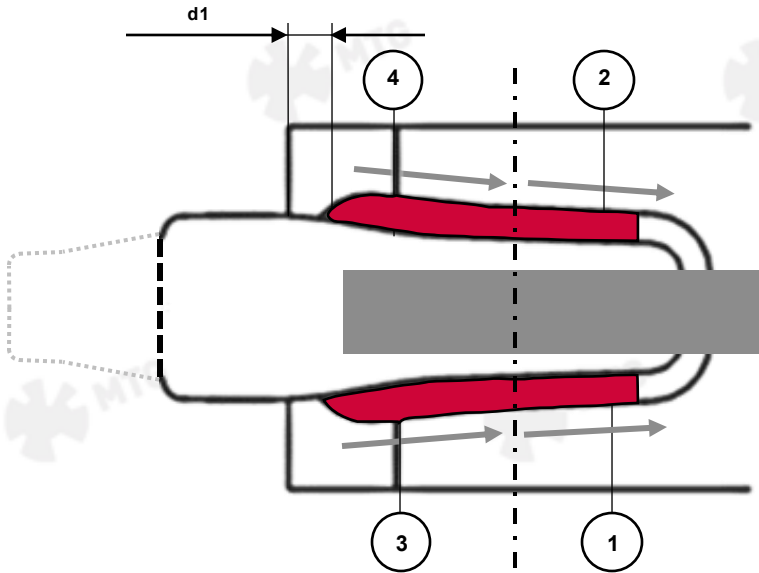

SIZE	d1	
	[MM]	[INCHES]
≤ 60	10 - 15	3/8 - 9/16
≥ 60	20 - 25	13/16 - 1

5.1.5 Repeat this sequence (step 5.1.4) three times. Vary the length of the beads slightly so that the start/stop positions are not at exactly the same location.

5.1.6 Flip the lip/bucket over.

5.1.7 Begin welding at the front of the weld groove on the bottom leg and weld to the back of the leg. Do not weld within “d1” distance from the lip leading edge, as indicated in point 5.1.4.

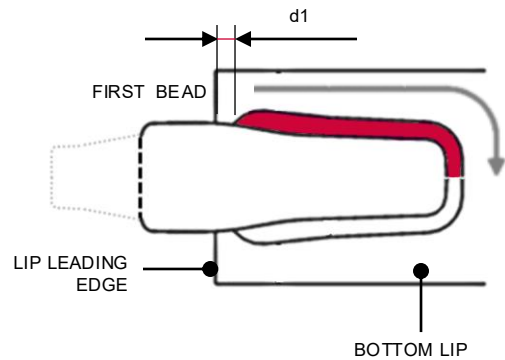
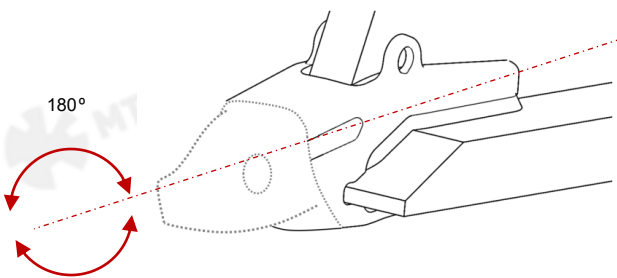

5.1.8 Begin welding at the front of the groove on the opposite side of the leg, joining the initial bead at the back of the leg.

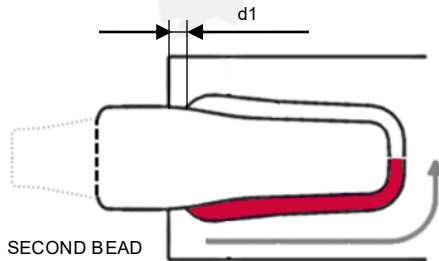

5.1.9 Repeat this sequence (steps 5.1.7 and 5.1.8) three times. Vary the length of the beads slightly so that the start/stop positions are not at exactly the same location.

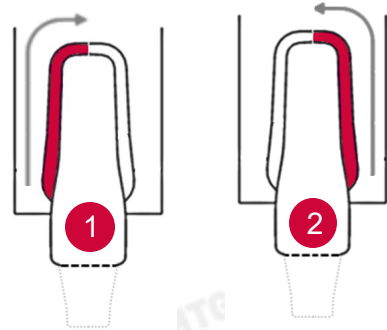

5.1.10 Adapters with bigger dimensions requires additional weld layers, turn the lip over and weld **three layers** according to the sequence for the top leg (steps 5.1.3, 5.1.4 and 5.1.5).

5.1.11 Flip the lip/bucket over again and apply three layers according to the sequence for the bottom leg (steps 5.1.7 and 5.1.8).

5.1.12 The leg sizes of the fillet must be flush and less than 3.2mm - 1/8 in. above the edge of the cast weld groove. In some adapter patterns, the weld groove height decreases near the leading edge of the lip. With these adapters, the size of the fillet shall decrease correspondingly in the region.

5.1.13 Ensure that the welding technique comply with what is exposed on the document entitled: "General welding recommendations".

5.2 WELD FINISHING

5.2.1 When welding large adapters, considerable grinding effort can be saved by carefully positioning the starting points of the beads near the leading edge. Start each bead slightly behind those of the preceding layer to produce a "rounded" weld end.

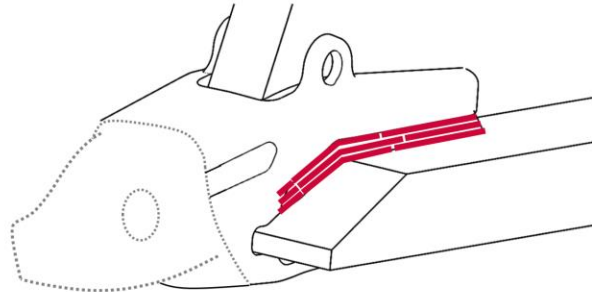

5.2.2 The surfaces of adapter/lip fabrication welds shall be ground smooth 65 to 75mm - 2½ to 3 in. from the front ends as indicated in the figure. All welds on both the top and bottom of the lip shall be ground.

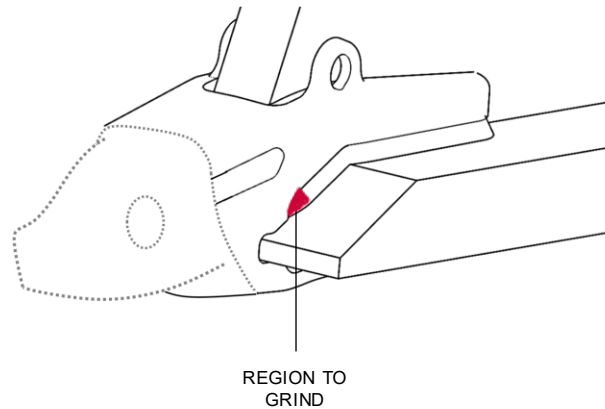

5.2.3 Grinding shall produce a smooth surface free of roughness and unevenness associated with the weld beads. The toes of the welds shall merge smoothly with the lip and the adapter with a minimum radius of 4mm - 5/32 in.



5.2.4 Grinding shall be done using high speed electric or pneumatic grinders with grinding wheels no larger than 50mm - 2 in. in diameter. **ANGLE HEAD OR DISK GRINDERS ARE NOT ALLOWED FOR THIS WORK.**

Grinding shall be done with the perimeter of the wheel and not the face. The grinding direction must be perpendicular to the toes of the welds as in the illustration.

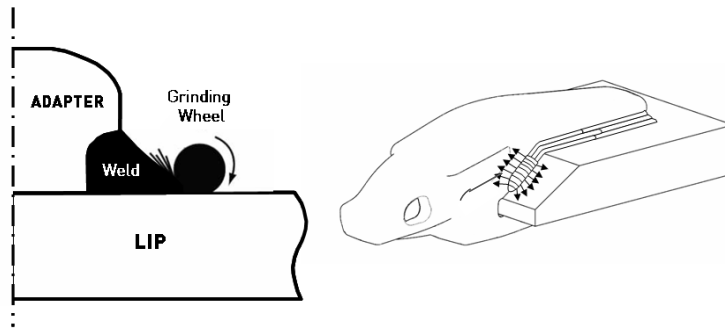

Proper Grinding Directions:

Grinding the radio at the toes of the welds is facilitated using cone-shaped grinding wheels. For final grinding, the abrasive may be no coarser than 24 Grit.

5.2.5 On adapters from size 50 (aprox from 30 to 60 tons) onwards, it is recommendable to perform a TIG dressing on both upper and lower adapters' straps. This process involves using a GTAW torch to make an autogenous weld pass along the toe of the weld fillet.

The welding power supply shall have high-frequency start capabilities. "Scratch-starting" is not allowed. It is preferable to employ a remote foot-pedal current control to permit suitable filling of craters at the ends of beads.

GTAW

PROCESS	GTAW	
ELECTRODE TYPE	AWS EWTh-2 (2% THORIATED)	
ELECTRODE DIA.	2.4mm to 4.0 mm / 3/32 to 5/32in.	
SHIELDING GAS	100% ARGON	
GAS CAP SIZE	13mm/0.50in.	
GAS FLOW RATE	9.4 to 14.2 l/minute / 20 to 30 ft ³ /hour	
CURRENT SIZE	DIRECT	
POLARITY	STRAIGHT (ELECTRODE NEGATIVE)	
CURRENT RANGE	2.4mm / 3/32in.	175 to 250 AMPERES
	3.2mm / 1/8in.	250 to 300 AMPERES
	4.0mm / 5/32in.	400 to 500 AMPERES
ELECTRODE TO WORK DISTANCE	1.6mm TO 3.2 mm / 1/16 TO 3/32in.	

5.2.6 The GTAW dressed is recommendable to be performed along to the weld toes on the top and bottom legs.

Any defects along the toes of the welds must be corrected by grinding or repair welding before the GTAW process. The torch shall be positioned over the weld toe and shall be oriented to produce a smooth weld bead without undercut. The welder shall control the travel speed to obtain a bead ranging from 4.8 to 8mm - 3/16 to 5/16 in. wide.

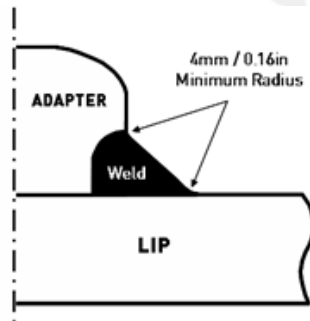

The welding area where the process shall be performed is the welding toe of both joining beads (red lines, on the image on the side).

Remember to perform the finishing process on the top and bottom leg and surpass the bevel of the blade by 20mm - 3/4 in.

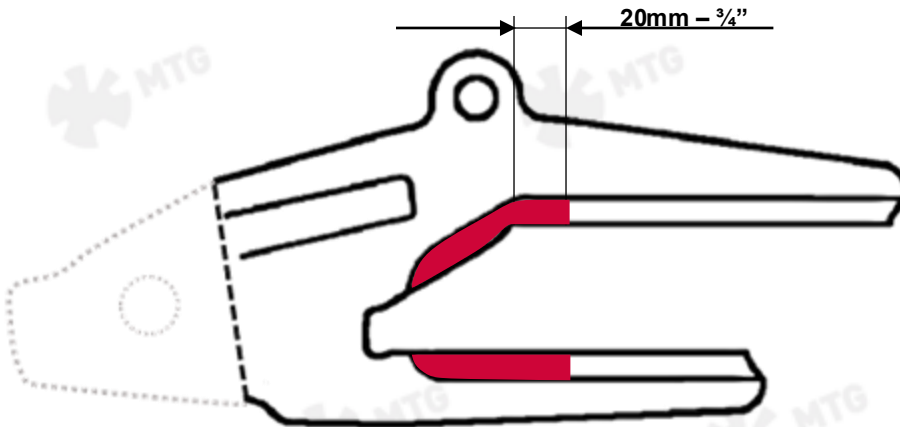

5.2.7 Repeat the sequence at all the rest of stations.

5.2.8 Another finishing recommendation for sizes from 120 and bigger is to perform a weld toe peening or a HFMI (High Frequency Mechanical Impact). For more information of both processes, please, refer to the document "General welding recommendations".

5.2.9 After completion of welding, all welds shall be subjected to visual and magnetic particle inspection. Any detected welding crack must be cleaned and repaired.



Service Instructions

The latest welding recommendations and assembly / disassembly instructions can be found online:

www.mtgcorp.com/manuals

Please contact Technical Services in case of questions:

technical.services@mtgcorp.com



MTG HEADQUARTERS

Carrer d'Àvila, 45
08005 Barcelona (Spain)
(+34) 93 741 70 00
info@mtgcorp.com

MTG NORTH AMERICA

4740 Consulate Plaza Drive
Houston, TX 77032 (USA)
+1 (281) 872 1500
Info.na@mtgcorp.com

MTG AUSTRALIA

16 – 18 Thorpe Close
Weishpool, WA, 6106 (AUS)
+61 8 6248 6513
Info.au@mtgcorp.com